



Rewarding Learning

ADVANCED
General Certificate of Education
2024

Centre Number

--	--	--	--	--

Candidate Number

--	--	--	--

Physics

Assessment Unit A2 3A

assessing

Practical Techniques and Data Analysis

MV18

[APH31]

FRIDAY 10 MAY, MORNING

Time

1 hour, plus your additional time allowance.

Instructions to Candidates

Write your Centre Number and Candidate Number in the spaces provided at the top of this page.

You must not communicate with any candidate during this examination.

Write your answers in the spaces provided in this question paper. Answer **both** questions.

The Supervisor will tell you the order in which you are to answer the questions. Not more than 28 minutes are to be spent in answering each question, and after 26 minutes you must stop using the apparatus in Questions 1 and 2 so that it can be rearranged for the next candidate. At the end of the 28 minute period you will be instructed to move to the station for the next question. At the end of the Test a 4 minute period will be provided for you to complete your answer to any question, but you will not have access to the apparatus during this time.

Information for Candidates

The total mark for this paper is 40.

Figures in brackets printed at the end of each question indicate the marks awarded to each question or part question.

You may use an electronic calculator.

Blank Page
(Questions start overleaf)

- 1 In this experiment you will investigate the oscillations of a loaded metre rule suspended in the horizontal position.

Aims

The aims of the experiment are to:

- vary the mass m suspended at the midpoint of the metre rule and record measurements of the time period for oscillations of the rule;
- analyse the data and plot a linear graph;
- use the graph to determine the mass of the metre rule, M_R .

Apparatus

The apparatus in **Fig. 1.1** has been set up for you. The metre rule is pivoted at the 1 cm mark P and is suspended at the 99 cm mark C by a helical spring hanging from a clamp.

A 200 g mass m is suspended at the 50 cm midpoint of the rule.

You have been provided with a stop clock.

Fig. 1.1

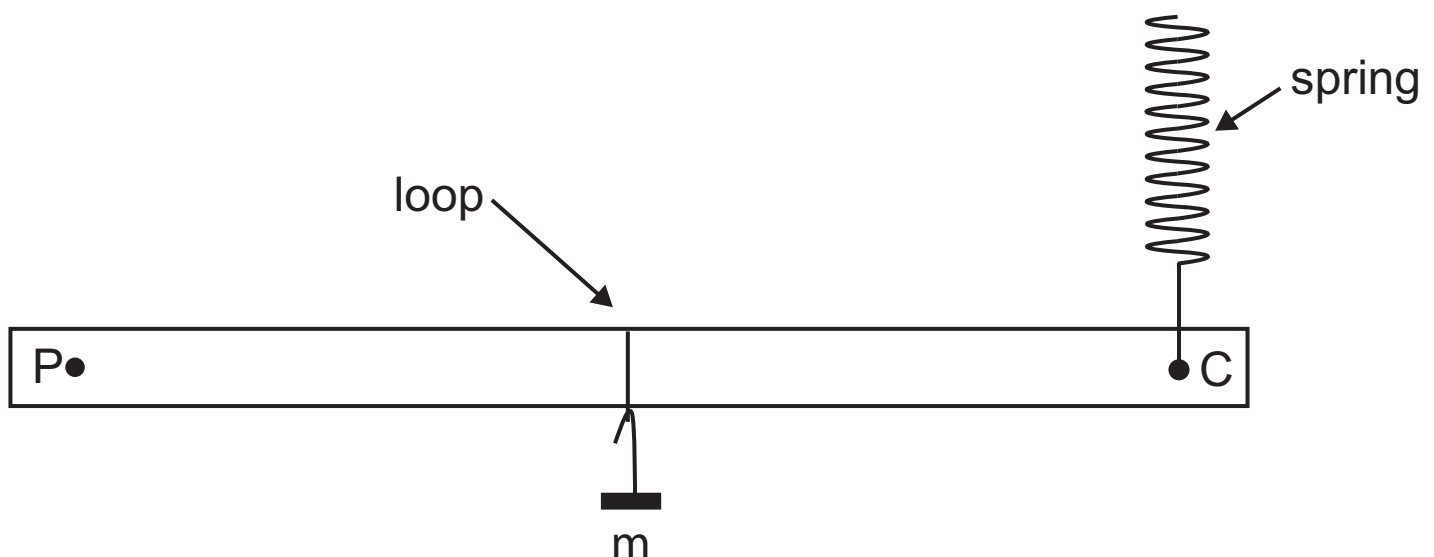

Procedure

(a) Displace the metre rule vertically at end C by a small distance and release, to start it oscillating.

Take readings to allow you to determine an accurate value for the period of oscillation T .

Record all your results in **Table 1.1**, adding additional column headings as required.

Increase the mass m by 100 g.

Adjust the position of the clamp holding the spring until the metre rule appears to be horizontal and the spring vertical.

Repeat this procedure for the values of m shown in **Table 1.1**. [4 marks]

Table 1.1

m / g		T / s	
200			
300			
400			
500			
600			

Blank Page

Analysis

The relationship between T and m is given by

Equation 1.1

Equation 1.1

$$T = C (m + M_R)^{\frac{1}{2}}$$

where C and M_R are constants, where M_R is the mass of the metre rule.

- (b) (i) Show that a graph of T^2 against m will be a straight line. [3 marks]

- (ii) In order to draw this graph, it is necessary to calculate values of T^2 . Complete the final blank column of **Table 1.1** with these values. Head the column appropriately. Record all values to 2 decimal places. [2 marks]

(iii) Draw a graph of T^2 against m opposite, starting both scales at zero. Select a suitable scale and label the y-axis on **Fig. 1.2**. Plot the points and draw the best fit straight line for the points plotted. [4 marks]

(c) (i) Determine the gradient of your best fit line. State the unit of the gradient. [3 marks]

Gradient = _____

Unit = _____

Fig. 1.2

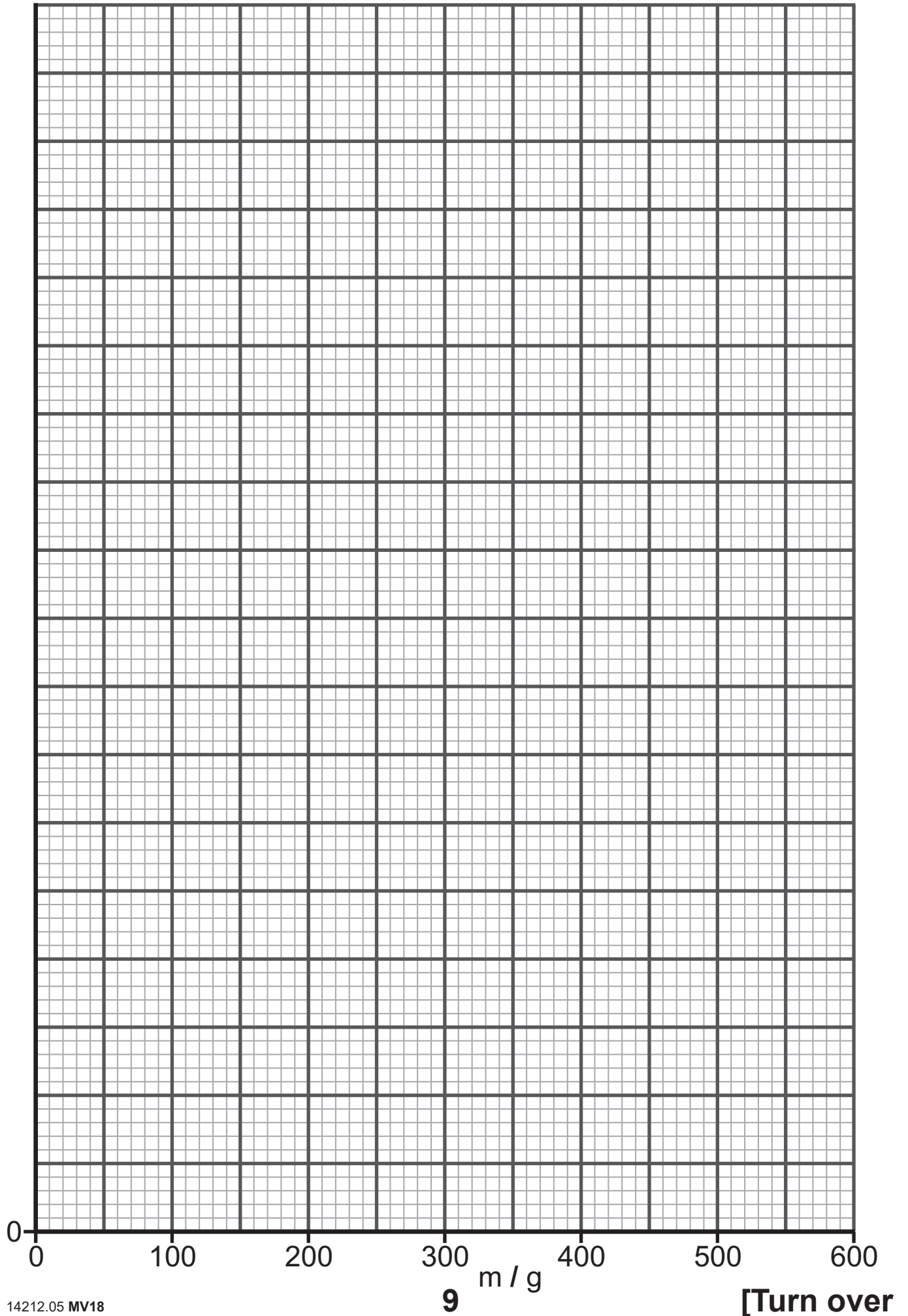

- (ii) Use the value for the gradient to calculate a value for the constant C. [1 mark]

C = _____ no unit required

- (iii) Use your graph and the value of C to determine the mass of the metre rule M_R . [3 marks]

M_R = _____ g

Blank Page
(Questions continue overleaf)

- 2 In this experiment you will investigate the refraction of light as it passes through a rectangular transparent block.

Aims

The aims of the experiment are to:

- trace the paths of rays of light through the transparent block for a range of angles of incidence;
- measure the angle of refraction for each angle of incidence;
- measure the distance of the position of the emergent ray from one end of the block;
- plot a linear graph of your results and use it to determine the value of a constant.

Apparatus

You are provided with a rectangular transparent block, a ray box, a protractor, a ruler and sheets of white paper.

Procedure

(a) Place the block centrally on one of the sheets of white paper provided and draw around the block. Remove the block and on one of the long sides, mark a point P exactly 20 mm from the short end of the block, as shown in **Fig. 2.1** opposite.

Draw the line NN', normal to the block at P and through the block. Draw a line to indicate the path of an incident ray at point P, with an angle of incidence of 15° .

Label this line 15 for your reference.

Fig. 2.1

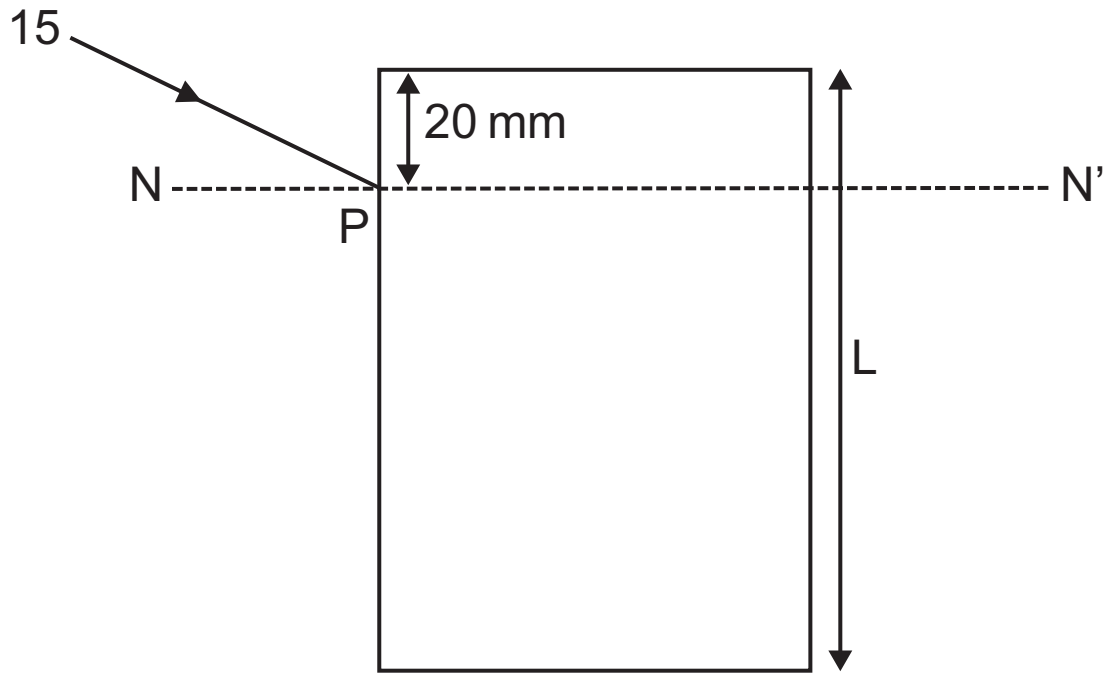

- (i) Measure the length L of the long side of the transparent block and record it below. [1 mark]

Length $L =$ _____ mm

- (ii) Replace the block on its outline and use the ray box to direct a ray of light along the path of the incident ray you have drawn. Mark the path of the emergent ray. Remove the block and complete the path of the refracted ray, as shown in **Fig. 2.2**.

Measure the angle of refraction r and the distance d from the point of emergence to the bottom of the block, as shown. Record your results in **Table 2.1**.

Fig. 2.2

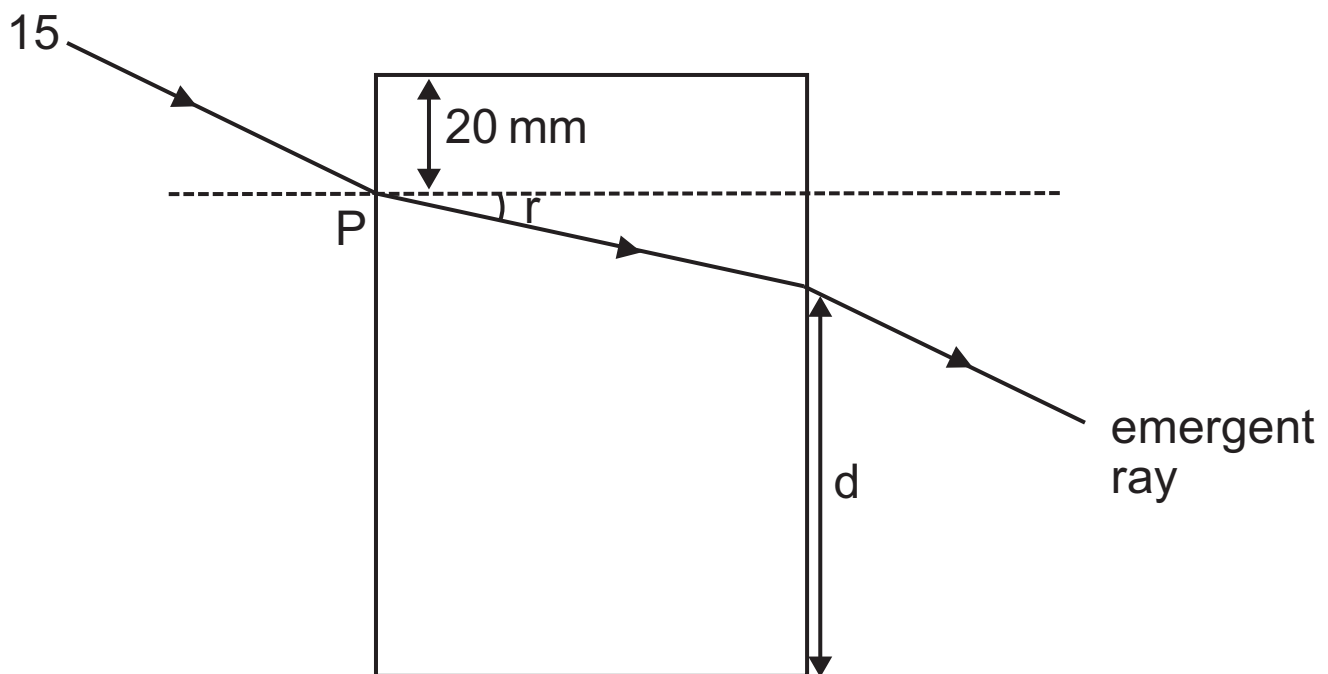

Repeat the procedure for two more angles of incidence of 30° and 45° on the same diagram on the sheet of paper.

Repeat the whole procedure for angles of incidence 60° and 75° on a second sheet of paper.

[4 marks]

Table 2.1

Angle of incidence / °	Angle of refraction r / °	d / mm	$\tan (r / °)$
15			
30			
45			
60			
75			

The sheets of paper showing your diagrams are to be enclosed in this answer booklet and handed in. Write your centre number and candidate number at the top of each sheet.

Analysis

Equation 2.1 gives the relationship between r and d

Equation 2.1

$$\tan r = \frac{B - d}{A}$$

where A and B are constants.

- (b) (i)** Show that a graph of d against $\tan r$ will be linear and state how the constants A and B can be determined from your graph. [4 marks]

A _____
B _____

- (ii)** Complete the final column on **Table 2.1** on page 15 with appropriate values recorded to 2 significant figures. [2 marks]

- (iii)** Draw the graph of d against $\tan r$ on the grid of **Fig. 2.3** on page 18. Select suitable scales and label the axes.
Draw the line of best fit for the points plotted.
[5 marks]

(c) (i) Use your graph to determine the value of constant B. [2 marks]

B = _____ mm

Fig. 2.3

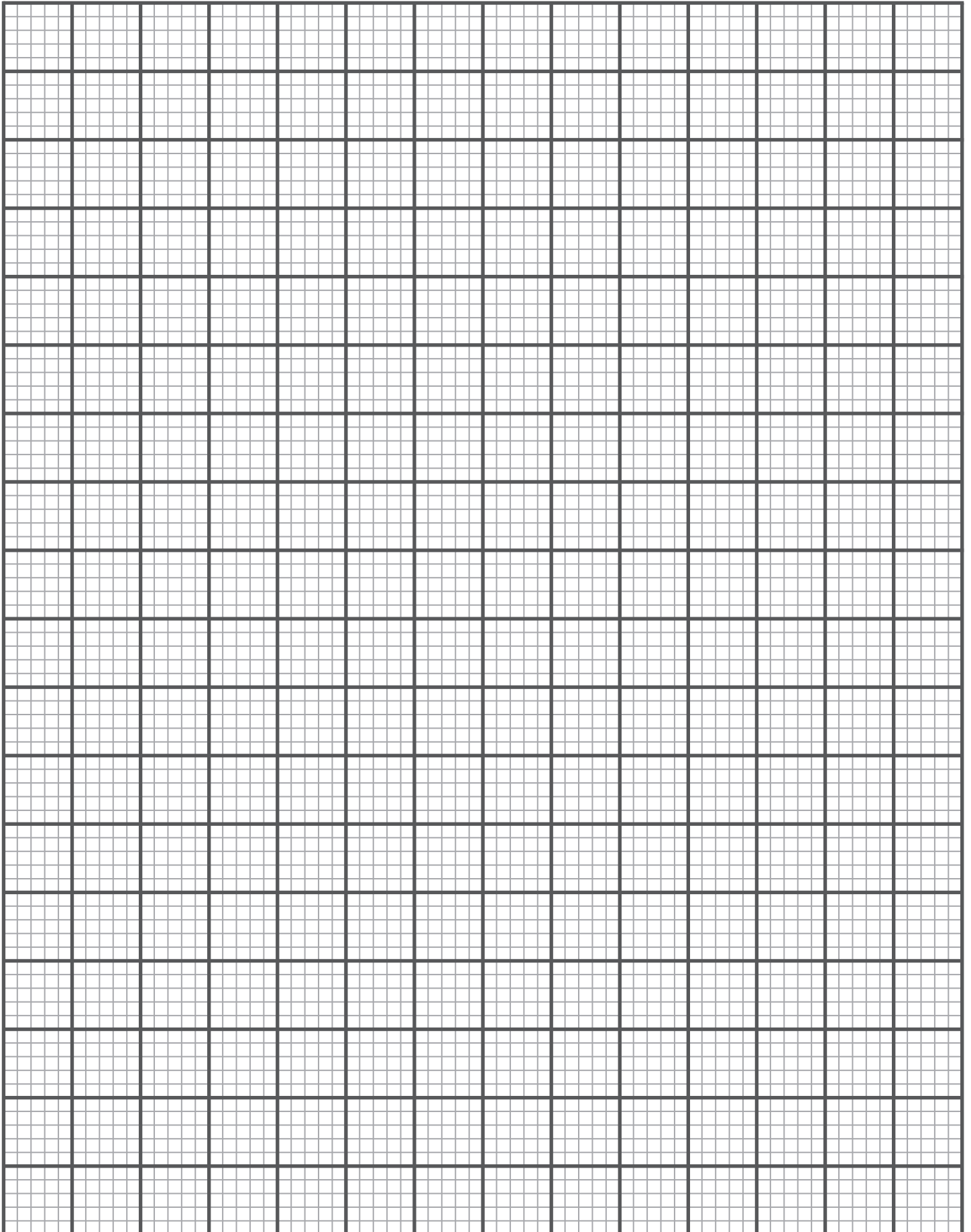

- (ii) Theory shows that $L = B + 20$. Calculate the percentage uncertainty between the value of L calculated using B and the more accurate value of L measured in (a)(i). [2 marks]

% uncertainty in $L =$ _____

This is the end of the question paper

For Examiner's use only		
Question Number	Marks	Remark
1		
2		
Total Marks		

Permission to reproduce all copyright material has been applied for.
In some cases, efforts to contact copyright holders may have been unsuccessful and CCEA will be happy to rectify any omissions of acknowledgement in future if notified.



Rewarding Learning

ADVANCED
General Certificate of Education
2024

Physics

Assessment Unit A2 3A

Practical Techniques and Data Analysis

[APH31]

FRIDAY 10 MAY, MORNING

APPARATUS AND MATERIALS LIST

To be accessed by Head of Department only

PHYSICS UNIT 3 (A2 3A)
APPARATUS AND MATERIALS REQUIRED FOR PRACTICAL ASSESSMENT

CONFIDENTIAL

This document gives preliminary information on the apparatus and materials required for the A2 Practical Assessment.

Information about the apparatus and materials required for this assessment must NOT be communicated to students. If apparatus/materials have their serial code and/or manufacturer specified then it is essential that centres use this exact apparatus/material.

On receipt of this APPARATUS AND MATERIALS LIST, centres must contact Gavin Gray, ggray@ccea.org.uk immediately if they have difficulty in sourcing the specified apparatus or materials.

Teachers will be given detailed instructions for setting up the experiment in the *Confidential Instructions for Physics Practical Test*, to which they will have confidential access from April 2024.

Teachers will have confidential access to a copy of the experimental test two working days (48 hours) before the start of the assessment.

The A2 3 Practical Techniques Assessment is a test of practical skills consisting of **two** experimental tests (40 marks). The duration of the assessment is 1 hour.

The apparatus in the following list will allow for **one experiment** to be set up for the practical test which makes up questions 1–2. In other words, each set of apparatus (as listed on **page 3**) will accommodate two candidates when doing the circus of experiments.

The apparatus can be used for alternative sessions according to the following schedule:

Friday 10th May 2024 Physics A2 3A (APH31)

(Main Session) **9.15 am–10.15 am**
(First Alternative) **10.30 am–11.30 am**
(Second Alternative) **11.45 am–12.45 pm**
(Third Alternative) **1.15 pm–2.15 pm**
(Fourth Alternative) **2.30 pm–3.30 pm**

One set of apparatus for A2 3A (APH31) will therefore be sufficient for ten candidates on **Friday 10th May** if the Main Session and all four alternatives are used. A laboratory may contain one, two, three or more sets of apparatus. This means that two, four, six, eight or more candidates can be accommodated in the same session. **To maintain the confidentiality of details of the practical tests, candidates entered for any of the alternative sessions must be segregated within the centre so that there can be no contact with candidates who have taken an earlier test in any centre.**

IMPORTANT NOTICE

Centres are urged to order items needed for the Physics Practical Test from the suppliers as soon as possible.

Question 1

Component

- 1 × wooden metre rule, mass >100 g
- 1 × helical spring, unextended length 20 mm, e.g. Timstar SP13863, PH B8A41397
- cord/string
- 1 × 100g mass hanger
- 5 × 100g masses
- 1 × large cork and optical pin
- 2 × retort stand, boss-head, clamp
- 1 × stop clock reading to 2 d.p.
- sellotape

Question 2

Component

- 1 × rectangular transparent block approx. 115 mm × 65 mm
- 1 × ray box
- 1 × single-slit
- 1 × 12V d.c. power supply
- 1 × 30 cm ruler
- 1 × protractor to $\pm 1^\circ$
- 2 × A4 sheets of blank white paper

Suppliers of transparent blocks:

betterequipped.ie product 0136

Selected school supplies product 100290

WF (Timstar) product OP11810



Rewarding Learning

ADVANCED
General Certificate of Education
2024

Physics

Assessment Unit A2 3A

Practical Techniques and Data Analysis

[APH31]

FRIDAY 10 MAY, MORNING

CONFIDENTIAL
INSTRUCTIONS

1 Confidential Instructions

These instructions will give detailed guidance on setting up and testing the apparatus and materials to be used. **Again, information contained within the Confidential Instructions must not be relayed to candidates under any circumstances.** If at this point, centres find that the testing process produces results different to those specified in the Confidential Instructions, they must contact the CCEA Science Officer (ggray@ccea.org.uk) immediately.

2 Final Apparatus Testing

The practical assessment question paper will be made available to the Head of Physics **two** working days before the timetabled starting time so that teachers and technicians can carry out a final test on the experiments. If on checking the apparatus gives unexpected results, the CCEA Physics Subject Officer should be contacted immediately (ggray@ccea.org.uk), if the problem cannot be resolved. Then the centre must e-mail the CCEA Physics Subject Officer stating the centre name and number, the specific nature of the problem and the range of anomalous results produced. CCEA will respond by acknowledging receipt of the e-mail. If you do not receive a response within 24 hours, please contact the CCEA Physics Subject Officer by telephone (028 90261200) to confirm that CCEA has received your e-mail.

3 Practical Assessment A2 3A

The A2 3A Practical Techniques Assessment is a test of practical skills comprised of 2 experimental tests. The duration of the assessment is 1 hour. Some of this time will be set aside for supervisors to re-set the apparatus ready for the next candidates. The assessment should be run as a circus of experiments with candidates moving to the next experiment at the designated time. The assessment should be timed as follows:

Questions	Time
Q1 (practical test)	26 minutes
Changeover and practical write-up	2 minutes
Q2 (practical test)	26 minutes
Changeover and practical write-up	2 minutes
End of test write-up	4 minutes

At the end of the 26 minute period, candidates must stop using the apparatus. During each 2 minute changeover period candidates may continue with their write up, however they will not have access to the apparatus. At the end of the test a 4 minute period is provided to complete their answer to any question, but will not have access to the apparatus.

4 After the Practical Assessments

When the individual exam sessions have finished, please return the A2 3A practical scripts together with the corresponding advice notes to the examinations officer (EO). We will collect these by the day after the examination. If we don't, please contact us immediately to arrange another time for collection.

Where the centre finds that a candidate may have been disadvantaged because the apparatus did not function as intended, the supervising teachers should make a report to the EO. The EO will forward the confidential report on the issue and the candidates affected to the centre support section at CCEA for special consideration. Candidates should be identified by their examination number.

IMPORTANT NOTICE

Centres are urged to order items needed for the Physics Practical Tests from the suppliers as soon as possible.

Confidential Instructions

Question 1

Requirements

- 1 × wooden metre rule
- 1 × helical spring (identical for each station)
- cord/string
- 1 × 100g mass hanger
- 5 × 100g masses
- 1 × large cork and optical pin
- 2 × retort stand, boss-head, clamp
- 1 × stop clock reading to 2 d.p.
- sellotape

Preparation

Drill small holes at the 1 cm and 99 cm marks of the metre rule.

Make a loop of string which will hold the mass hanger and secure the loop at the 50 cm mark on the rule with sellotape.

Clamp the cork with the optical pin inserted at a height of *approx.* 25 cm above the desk.

Attach the spring at the 99 cm mark on the metre rule. Suspend the rule with the optical pin through the 1 cm mark and the loop of the spring hung over one claw of the clamp.

Place a 100g mass on the mass hanger and hang this from the loop of string.

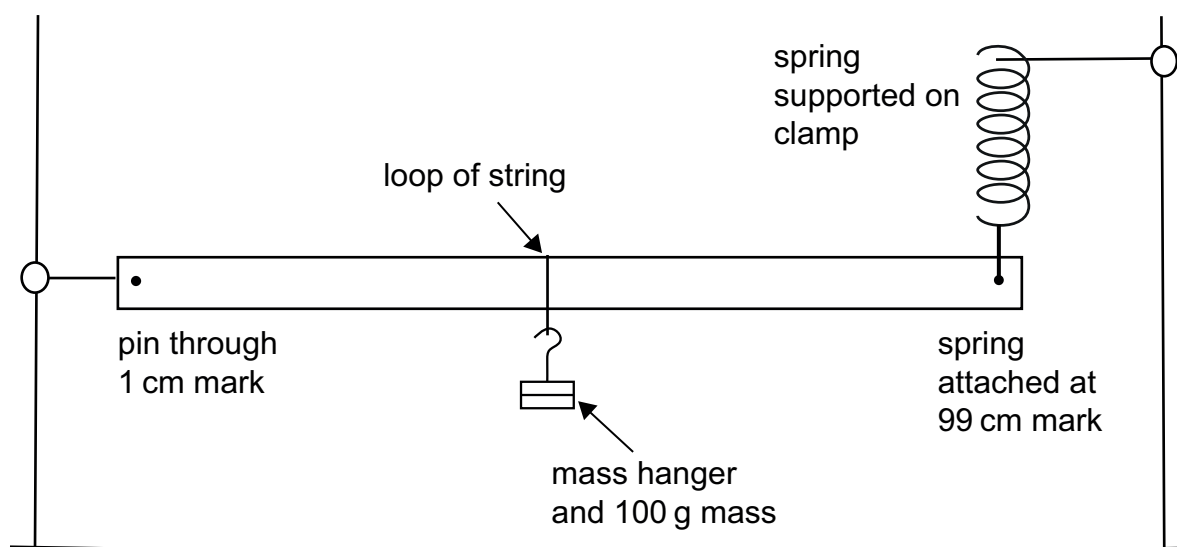

Fig. 1.1

Adjust the position of the boss-head supporting the clamp holding the spring so that the rule is horizontal, checking also that the spring is vertical. The final arrangement is shown in **Fig. 1.1**. Check that the metre rule can oscillate freely when displaced vertically.

Place a stop clock at each station.

Action at changeover

Remove any additional masses from the mass hanger so that $m = 200\text{ g}$. Check that the metre rule appears horizontal and the spring is vertical. Reset the stop clock.

Question 2

Requirements

- 1 × rectangular transparent block approx 115 × 65 mm
- 1 × ray box, single slit and 12V power supply
- 1 × 30 cm ruler
- 1 × protractor to $\pm 1^\circ$
- 2 × A4 sheets of blank white paper

Preparation

Set the power supply to 12V and connect to ray box with single slit in place. Check that incident rays of light (angles of incidence between approx. 15° and 75°) can be clearly seen emerging from the block on the opposite side of the block, when the arrangement is as shown in **Fig. 2.1**

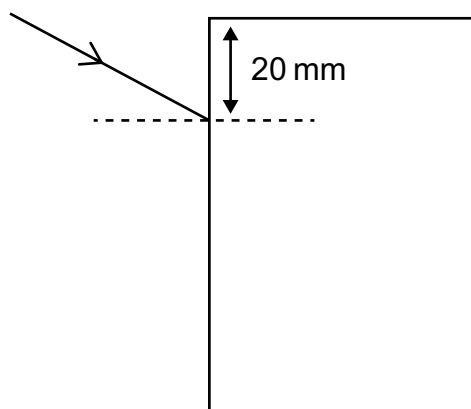

Fig. 2.1

Place the transparent block, 2 sheets of white paper, protractor and ruler beside the rest of the apparatus.

Action at changeover

Check power supply is at 12V. Remove any used sheets of white paper and replace. Place the transparent block, 2 sheets of white paper, protractor and ruler beside the rest of the apparatus.

At the end of the examination

Before they leave, ensure that each candidate's 2 × A4 sheets are placed securely within the answer booklet. The centre number and candidate number should be written at the top of each sheet.

